

PROPAC™ 10D Integrated Drainback system specifications:

- Fully integrated, self contained
- 160 ft² maximum collector surface area
- 320 gallons maximum storage tank capacity
- Freeze proofs collectors
- No remote valves
- No collector scaling
- TIG welded 304 stainless 10 gallon reservoir
- Serviceable Stainless Steel heat exchanger
- Quiet operation
- Pre-tested, Factory certified
- Compact design
- Over temperature protected
- Dual bronze pumps

Approved for use with these fine collector brands:

- APRICUS
- CHROMAGEN
- HELIODYNE
- SOLAR ROOFS
- SOLENE
- SUN EARTH
- SUN LABS
- TCT SOLAR

The **PROPAC™** from Energy Labs is a fully assembled solar heating system fluid handling package. It employs the proven, reliable, low maintenance system configuration known as "DrainBack". All pumps, valves, plumbing, sensors, controls and heat exchanger are installed and tested prior to shipment. When the **PROPAC™** arrives it is fully ready to connect to your heating system without further assembly. Collector interconnect lines can be either copper or PEX. All **PROPAC™** systems are equipped with an innovative, intelligent control system that maximizes energy capture from the solar array. All sensors are included along with instructions and a warranty card.

The DRAINBACK system configuration for solar heating is the single most trouble free, reliable and least costly to install active type system. Drainbacks are the easiest to operate and maintain. Years of field experience have gone into the design of the PROPAC™ heat transfer units. A unique feature of the PROPAC™ is its ability to be installed in the most advantageous location. It can be remote from either the collectors or the system load storage, or both. There are no valves of any kind required in the collector array or piping.

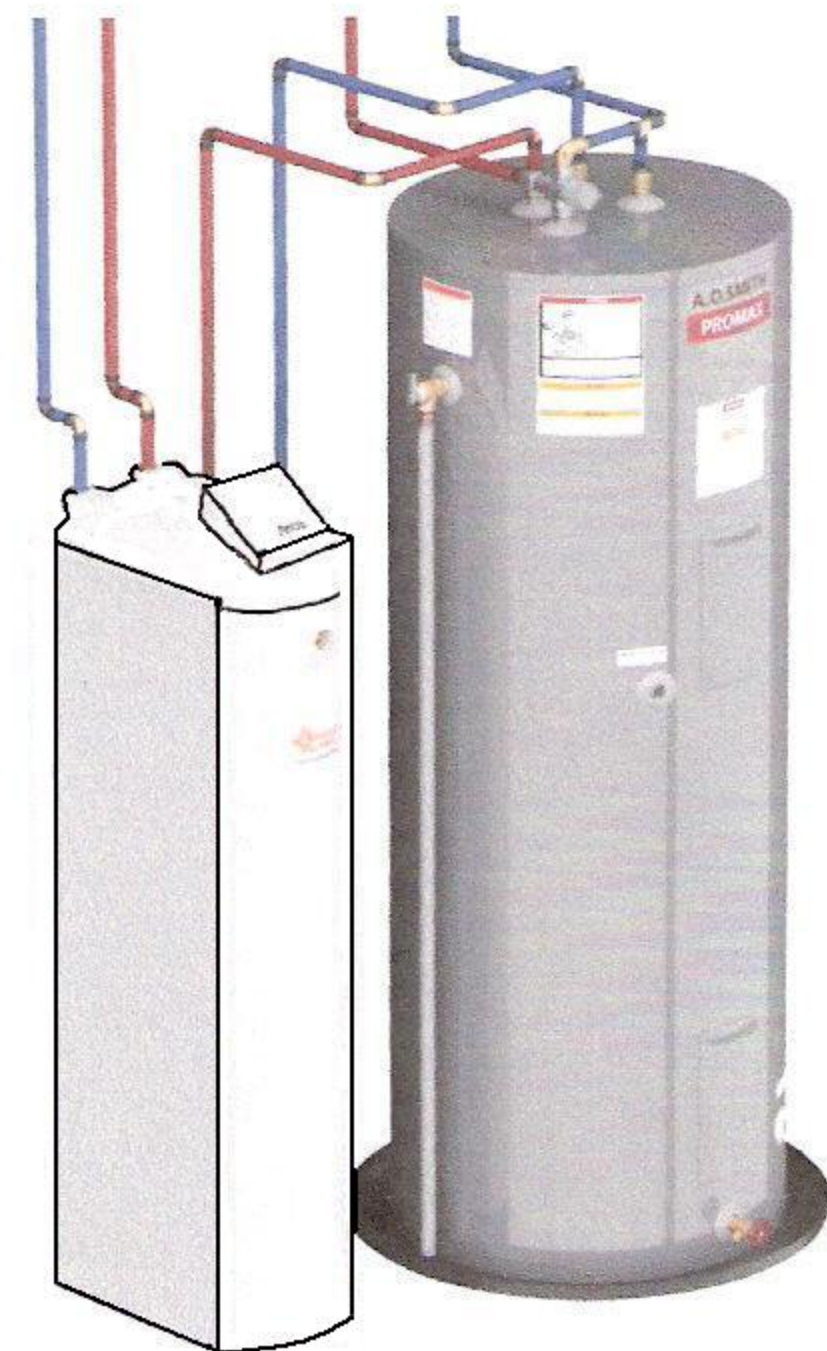

PROPAC 10D

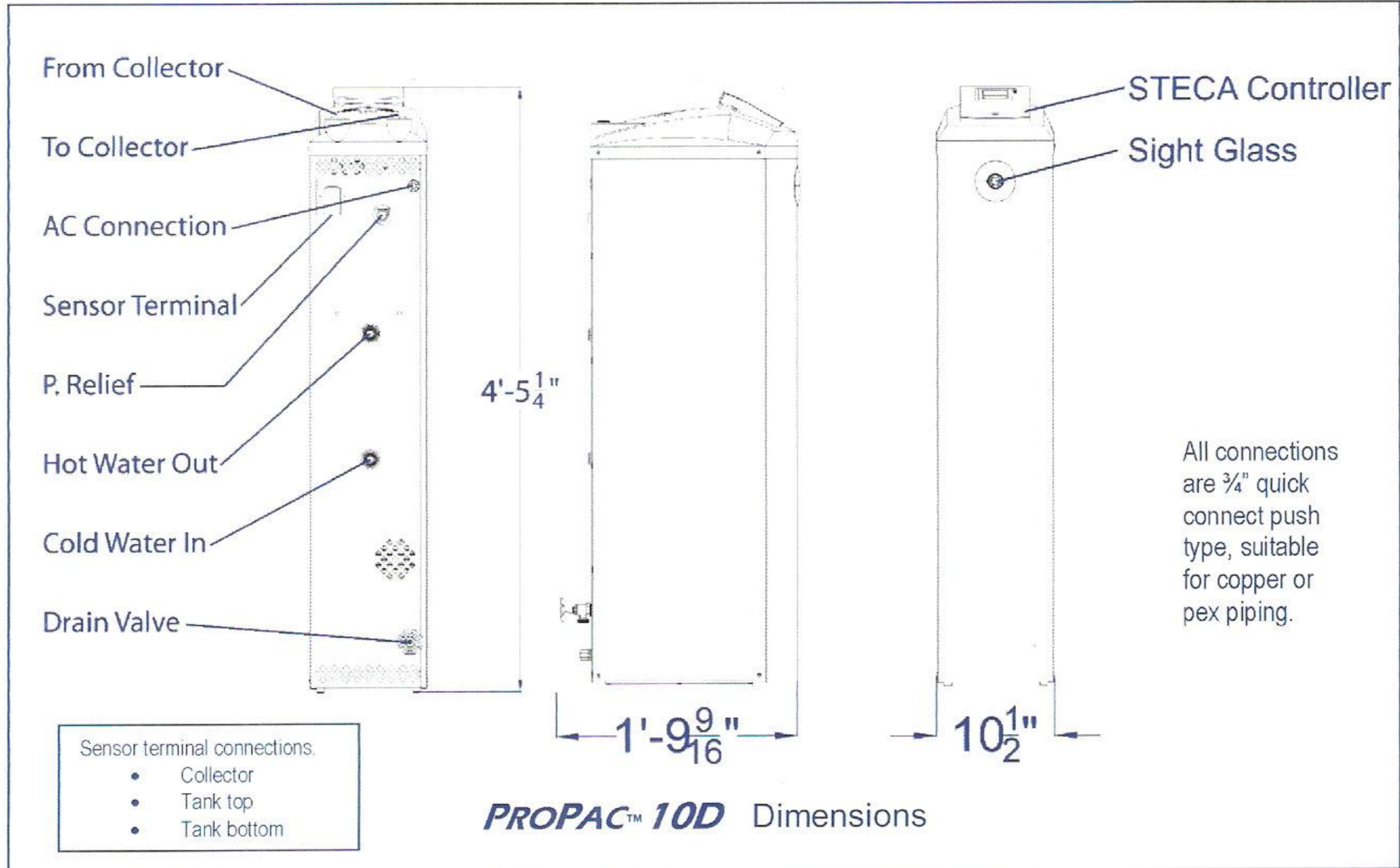

PROPAC™ 10D
Technical DATA

Voltage:	120 VAC
Watts Operating:	219 W
Watts Idle:	<1W
Head capacity:	35 Ft
Tank capacity:	10 gal.
Heat exchanger:	Plate stainless steel
HX capacity:	50,000 Btu/hour
Operating temp. fluids:	33 °F to 200 °F (+1 °C to +93°C)
Collector temperature:	-70°F to 356 °F (-56 °C to +180 °C)
Ambient temperature:	33 °F to 113 °F (+1 °C to +45 °C)
Weight:	73 lb
Casing & Frame:	Aluminum

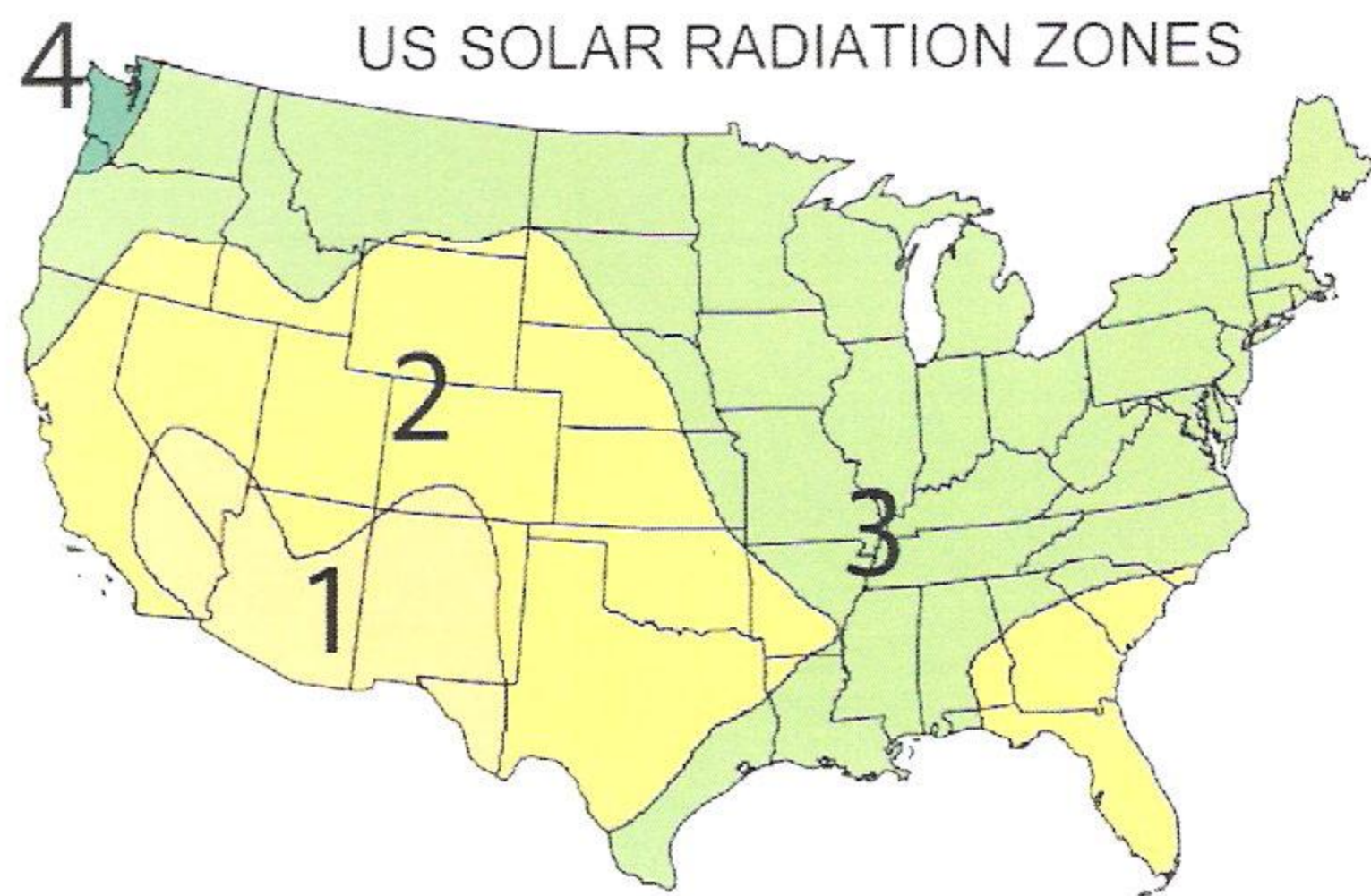

Collector surface area by radiation zone for flat plate collectors facing south tilted at latitude

Use the chart to the right for determining collector surface area sizing for different solar insolation levels with different size storage tanks. Choose tank size, then zone to determine collector square footage.

SYSTEM SIZE	Zone 1	Zone 2	Zone3	Zone4
50 Gallons	21 ft ²	26 ft ²	32 ft ²	40 ft ²
60 Gallons	28 ft ²	32 ft ²	40 ft ²	64 ft ²
80 Gallons	40 ft ²	40 ft ²	64 ft ²	80 ft ²
120 Gallons	64 ft ²	64 ft ²	80 ft ²	128 ft ²
240 Gallons	120 ft ²	120 ft ²	160 ft ²	240 ft ²